

## Original Investigation

# Association of *TMTC2* With Human Nonsyndromic Sensorineural Hearing Loss

Christina L. Runge, PhD; Amit Indap, PhD; Yifan Zhou, PhD; Jack W. Kent Jr, PhD; Ericka King, MD; Christy B. Erbe, BS; Regina Cole, BS; Jack Littrell, MS; Kate Merath, PhD; Roland James, MS; Franz Rüschenendorf, PhD; Joseph E. Kerschner, MD; Gabor Marth, PhD; Norbert Hübner, PhD; Harald H. H. Göring, PhD; David R. Friedland, MD, PhD; Wai-Meng Kwok, PhD; Michael Olivier, PhD

**IMPORTANCE** Sensorineural hearing loss (SNHL) is commonly caused by conditions that affect cochlear structures or the auditory nerve, and the genes identified as causing SNHL to date only explain a fraction of the overall genetic risk for this debilitating disorder. It is likely that other genes and mutations also cause SNHL.

**OBJECTIVE** To identify a candidate gene that causes bilateral, symmetric, progressive SNHL in a large multigeneration family of Northern European descent.

**DESIGN, SETTING, AND PARTICIPANTS** In this prospective genotype and phenotype study performed from January 1, 2006, through April 1, 2016, a 6-generation family of Northern European descent with 19 individuals having reported early-onset hearing loss suggestive of an autosomal dominant inheritance were studied at a tertiary academic medical center. In addition, 179 unrelated adult individuals with SNHL and 186 adult individuals reporting nondeafness were examined.

**MAIN OUTCOMES AND MEASURES** Sensorineural hearing loss.

**RESULTS** Nine family members (5 women [55.6%]) provided clinical audiometric and medical records that documented hearing loss. The hearing loss is characterized as bilateral, symmetric, progressive SNHL that reached severe to profound loss in childhood. Audiometric configurations demonstrated a characteristic dip at 1000 to 2000 Hz. All affected family members wear hearing aids or have undergone cochlear implantation. Exome sequencing and linkage and association analyses identified a fully penetrant sequence variant (*rs35725509*) on chromosome 12q21 (logarithm of odds, 3.3) in the *TMTC2* gene region that segregates with SNHL in this family. This gene explains the SNHL occurrence in this family. The variant is also associated with SNHL in a cohort of 363 unrelated individuals (179 patients with confirmed SNHL and 184 controls,  $P = 7 \times 10^{-4}$ ).

**CONCLUSIONS AND RELEVANCE** A previously uncharacterized gene, *TMTC2*, has been identified as a candidate for causing progressive SNHL in humans. This finding identifies a novel locus that causes autosomal dominant SNHL and therefore a more detailed understanding of the genetic basis of SNHL. Because *TMTC2* has not been previously reported to regulate auditory function, the discovery reveals a potentially new, uncharacterized mechanism of hearing loss.

*JAMA Otolaryngol Head Neck Surg.* doi:10.1001/jamaoto.2016.1444  
Published online June 16, 2016.

**Author Affiliations:** Author affiliations are listed at the end of this article.

**Corresponding Author:** Christina L. Runge, PhD, Department of Otolaryngology and Communication Sciences, Medical College of Wisconsin, 9200 W Wisconsin Ave, Milwaukee, WI 53226.

Hearing loss is one of the most common sensory defects in humans, affecting approximately 1 in 1000 newborns, with an estimated 50% having genetic causes.<sup>1,2</sup> Incidence of hearing loss is estimated as 0.5% in older children (aged 3-17 years)<sup>3</sup> and 17% in adults.<sup>4</sup> Sensorineural hearing loss (SNHL) is caused by conditions that affect the cochlear structures or the auditory nerve. In addition to genetic factors, environmental insults contribute to the development of SNHL.<sup>5-8</sup> A large number of genetic loci have been identified that contribute to autosomal dominant, autosomal recessive, X-linked, Y-linked, and mitochondrial forms of nonsyndromic SNHL.<sup>9</sup> Fifty-three independent genetic loci contributing to nonsyndromic autosomal dominant SNHL have been discovered, with 142 mutations in 31 genes identified. Similarly, more than 76 loci contribute to recessive forms of SNHL. However, those identified to date only explain a fraction of the overall genetic risk for SNHL, and more remain to be discovered.

Recommendations and outcomes of SNHL habilitation, such as hearing aids and cochlear implants, depend on myriad factors, and advances in genetic testing can provide useful etiologic information to aid clinical decisions. Initiatives to incorporate genetic testing in early hearing detection and intervention programs aim to inform the cause of congenital hearing loss in newborns and the risk of late-onset hearing loss in children.<sup>10,11</sup> Although clinical testing is expanding to identify mutations, much is still unknown about the genetic causes and molecular mechanisms of progressive SNHL, and the effect of genetic testing on clinical management of SNHL remains limited.

The objective of this study was to identify a candidate gene causing bilateral, symmetric, progressive SNHL in a multigeneration family of Northern European descent. Our analyses identified a sequence variant in a previously uncharacterized gene, *TMTC2* (OMIM 615856), that is strongly associated with SNHL in this family. The gene variant is also associated with SNHL in a group of unrelated individuals, suggesting that *TMTC2* may be of broader importance for normal auditory function.

## Methods

### Study Participants

Family members were recruited in Wisconsin and adjacent Midwestern US states from January 1, 2006, through April 1, 2016. All were of Northern European descent. Hearing loss status was reported by family members (for deceased and very young individuals), self-reported, or clinically assessed by standard audiometric testing. All available audiograms were used to calculate age-related typical audiograms, as described by Topsakal and colleagues.<sup>12</sup> Octave-frequency threshold values of the right ear were plotted by age and frequency-specific linear regression equations used to calculate threshold values for each decade of age from 0 to 70 years, which were then transposed to generate age-related typical audiograms.

In addition, unrelated adult volunteers of Northern European descent with confirmed SNHL requiring a cochlear im-

### Key Points

**Question** What is the genetic cause of progressive sensorineural hearing loss (SNHL) in a large multigeneration family?

**Findings** Exome sequencing and linkage and association analyses identified a fully penetrant sequence variant (*rs35725509*) on chromosome 12q21 (logarithm of odds, 3.3) in the *TMTC2* gene region that segregates with SNHL in the family. The variant is also associated with SNHL in a cohort of unrelated individuals.

**Meaning** A previously uncharacterized gene, *TMTC2*, was identified as causing progressive SNHL in humans. This finding identifies a novel locus and reveals a potentially new, uncharacterized mechanism of hearing loss.

plant or hearing aids were included who were patients of, or referrals to, our clinical program. A control group of adults of Northern European descent from the Midwestern US states who self-reported as not having deafness was also included.

All procedures were approved by the Children's Hospital of Wisconsin Institutional Review Board. Written informed consent was obtained from all study participants for this study and for publication. Data were deidentified for genetic analyses but not for phenotypic analyses.

### DNA Sample Collection

DNA was obtained from saliva, buccal swabs, or blood using Oragene Collection Kits and Oragene prepIT-LP2 reagent (DNA Genotek) for saliva, Isohelix T-Swabs (Boca Scientific) and PUREGENE DNA Isolation Kit (Gentra Systems) for buccal swabs, and the whole-blood PUREGENE DNA Isolation Kit (Gentra Systems) for blood. Extracted DNA was resuspended in Tris-EDTA buffer and stored at  $-20^{\circ}\text{C}$ .

### Linkage Analysis

DNA samples were genotyped using the Human SNP Array 6.0 (Affymetrix). Data were analyzed using the Genotyping Console software suite (Affymetrix) with default parameters. Any genotype that was inconsistent with mendelian segregation was blanked using SimWalk2.<sup>13</sup>

A subset of markers was selected for linkage analysis to minimize the linkage disequilibrium (LD) between adjacent variants. Only single-nucleotide polymorphisms (SNPs) with a minimal distance between markers of 25 000 bp and a minimum minor allele frequency of 0.25 were included. Two-point linkage analysis using 61 108 SNP markers was conducted in Sequential Oligogenic Linkage Analysis Routines (SOLAR)<sup>14</sup> using a probit liability model with ascertainment correction.<sup>15</sup>

### Resequencing

Six family members were analyzed by exome sequencing using the Agilent SureSelectXT All Exon V5 Target Enrichment System (affected individuals III:7, IV:6, IV:9, V:7, and V:11 and unaffected individual III:8). All samples were pair-end sequenced (Illumina GAII). Fastq files generated from CASAVA, version 1.8 were aligned with the human reference sequence

GRCh37 using standard protocols (details available on request). Sequence variants were called with FreeBayes, version 0.8.9 (<http://arxiv.org/abs/1207.3907>).

### Association Analysis

Association analyses were conducted in SOLAR<sup>14</sup> in the linkage cohort using SNP Array 6.0 genotype data. When necessary, proxy SNPs were selected using the SNP Annotation and Proxy Search (<https://www.broadinstitute.org/mpg/snap/>).

Genotype dosage scores were coded as 0, 1, or 2 copies of the SNP minor allele. Estimates of heritability were performed using a probit liability model with ascertainment correction.<sup>15</sup> Neither age nor sex was a significant correlate of hearing loss, and neither was included as a covariate in the analysis. Initially, each genotype dosage score was applied as a covariate to the liability model for hearing loss, and the likelihood of this model was compared with that of the null model of no association. The likelihood ratio test statistic is distributed as a  $\chi^2$  statistic. Bayesian model selection<sup>14</sup> was used to choose the most parsimonious model (details in the Results section) and minimize LD effects. The identified sequence variant was genotyped in additional members of the family and unrelated samples, using Invader technology.<sup>16,17</sup>

## Results

Nine family members (5 women [55.6%]) provided audiometric and medical records that documented hearing loss. The group of unrelated adult volunteers with confirmed SNHL included 179 individuals, with 146 requiring a cochlear implant and 33 requiring hearing aids (mean [SD] age, 82 [18] years; age range, 18-94 years; 94 women [52.5%]). The control group who self-reported as not having deafness included 186 adults (mean [SD] age, 64 [8] years; age range, 50-83 years; 125 women [67.2%]).

We initially analyzed a large multigeneration family of Northern European descent with a likely autosomal dominant form of bilateral, symmetric, progressive SNHL reaching severe to profound loss of hearing in childhood (**Figure 1**). **Figure 2A** and **B** show examples of the audiometric configuration and progression of hearing loss with age for family members III:7 and V:7 (right ear only). **Figure 2C** shows examples of available audiometric data for 3 of the unrelated individuals with SNHL of various ages who were ultimately found to have the same genetic mutation as the Wisconsin family (right ear only). Age-related typical audiograms from the Wisconsin family demonstrated progressive, high-frequency sloping hearing loss with a characteristic dip at 1000 to 2000 Hz and peak at 4000 Hz (**Figure 2D**).

The exact ages at hearing loss onset were not determinable; however, the earliest available audiograms and medical records were analyzed for the 9 individuals who provided them (**Table**). Clinical record data confirmed childhood-onset hearing loss for 6 family members. For the remaining 3 individuals, childhood onset was self-reported. All affected individuals are auditory-oral communicators

**Figure 1. Pedigree of a Family With Sensorineural Hearing Loss**

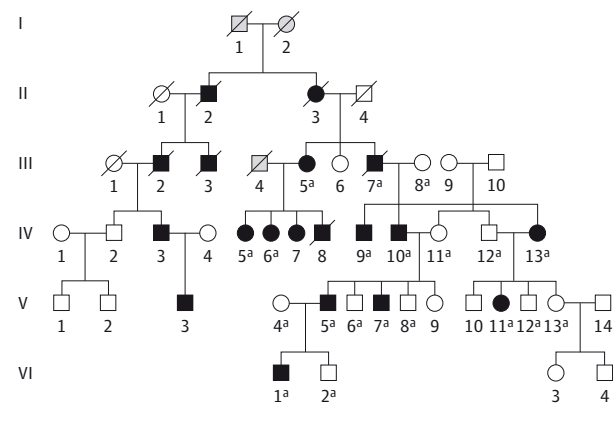

Hearing loss status was self-reported, reported by family members (for deceased and very young individuals), or based on records of audiometric tests. Individuals who provided audiometric records were III:7, IV:5, IV:6, IV:9, IV:10, IV:13, V:7, and V:11. Hearing loss was self-reported for III:5, IV:8 (before death), V:3, and V:5. Family members reported hearing loss for II:2, II:3, III:2, III:3, and VI:1. Deceased individuals with unknown hearing loss cause are indicated by gray symbols; all affected individuals are represented by filled symbols.

<sup>a</sup> Individuals included in the initial linkage analysis.

who wear hearing aids, and 2 family members have received unilateral cochlear implants (individuals III:7 and V:11). The 2 individuals with implants have had benefit from this intervention consistent with postlingual onset of severe to profound hearing loss.

To identify the gene causing the SNHL in this family, 20 individuals across 4 generations, including 11 affected individuals, were analyzed. Complete genotype data for all individuals were obtained on 631 644 variants. Two-point linkage analysis identified a region on chromosome 12q21 (logarithm of odds [LOD], 3.3) (**Figure 3**). The 1 – LOD CI spans 13 Mb (79-92 Mb, GRCh37/hg19) and contains 48 known genes. Three individual SNPs were strongly linked to SNHL (LOD, >3), and 53 additional SNPs had suggestive evidence of linkage (LOD, >2). None of the genes in this region has been implicated in autosomal dominant hereditary hearing loss,<sup>9</sup> and the linkage region does not overlap with any other SNHL loci. However, the region contains 2 genes, *PTPRQ* (OMIM 603317) and *OTOGL* (OMIM 614925), that have been identified at the *DFNB84* locus, causing an autosomal recessive form of SNHL.

As shown in **Figure 3**, the linkage analysis also uncovered a second region on chromosome 5q11.2-14.3 with suggestive evidence of linkage (LOD, 2.8). However, no evidence for linkage remains when the analysis is performed conditional on the locus on chromosome 12q (LOD, 0.18), suggesting that the locus on 12q21 harbors the causal gene for SNHL in this family.

To identify the likely causal gene in the linkage interval and to simultaneously explore the role of other previously reported loci for autosomal dominant hearing loss, we selected 6 individuals (III:7, III:8, IV:6, IV:9, V:7, and V:11) from the family for resequencing using exome capture. The sequence analysis revealed 84 357 SNP variants across the

Figure 2. Hearing Loss Phenotype

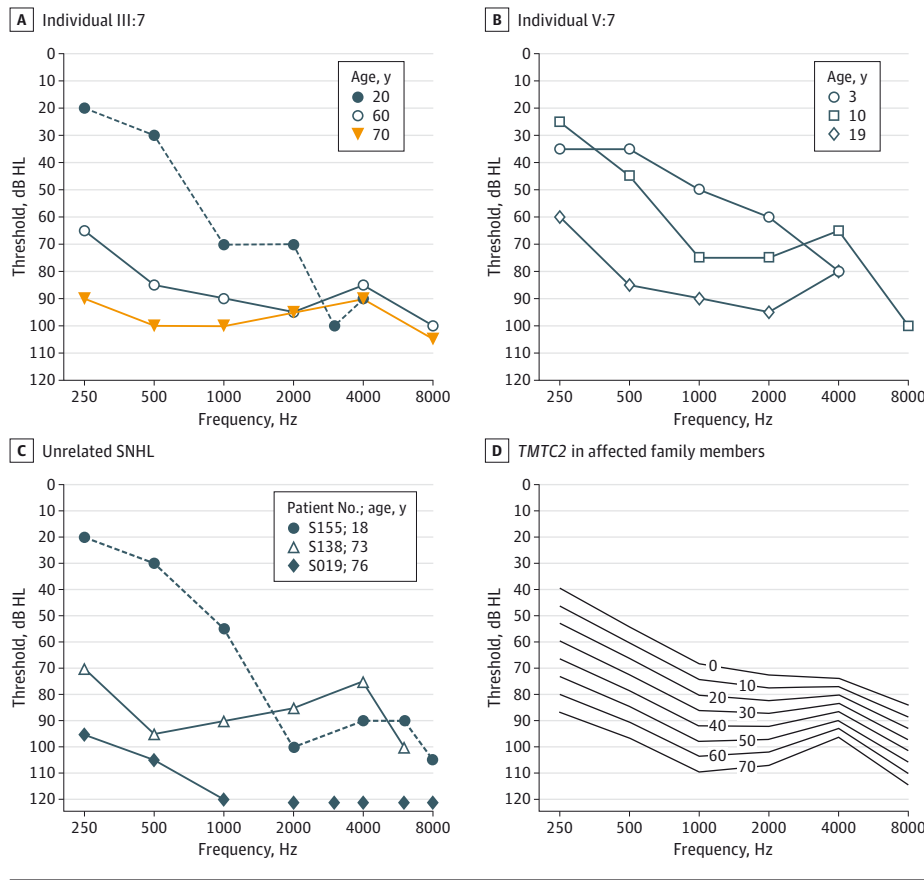

A and B, Serial audiograms showing progressive hearing loss from the right ear of 2 family members representing different generations. C, Audiograms from 3 unrelated individuals with sensorineural hearing loss (SNHL) who harbor the same mutation found in the Wisconsin family. D, Age-related typical audiograms calculated from right-ear audiograms of affected family members. db HL indicates decibels Hearing Level.

Table. Characterization of the Earliest Audiometric Data Available for the 9 Family Members Who Provided Records<sup>a</sup>

Pedigree	Age of Earliest Audiogram, y	3-PTA, dB	Degree of Hearing Loss	Comments
III:7	20	60	Mild to profound	Age, 20 years; medical record reported "deafness, partial, bilateral-since childhood"
IV:5	44	68	Moderate to severe	NA
IV:6	39	75	Moderate to severe	NA
IV:7	53	67	Mild to profound	NA
IV:9	11	85	Severe to profound	NA
IV:10	36	95	Profound	Age, 40 years; medical record reported "bilateral hearing problems as a child"
IV:13	16	87	Severe to profound	NA
V:7	2	30	Mild	SRT of 20 dB HL; SF testing
V:11	2	70	Moderate to profound	SF testing

Abbreviations: 3-PTA, 3-frequency pure tone average; db HL, decibels Hearing Level; NA, not available; SF, sound field; SRT, speech recognition threshold.

<sup>a</sup> The 3-PTA hearing thresholds were measured at frequencies of 0.5, 1, and 2 kHz. The SF testing was performed via speakers and only reflects thresholds of the better ear; however, given the symmetry of thresholds between ears at later evaluations, it was assumed the hearing losses were symmetrical.

genome. Because the resequencing included 1 unaffected founder (individual III:8) and 5 affected individuals, we postulated that the unaffected individual III:8 had to be homozygous for the reference allele, and 4 of 5 affected individuals (III:7, IV:9, V:7, and V:11) had to be heterozygous because 1 parent was unaffected. Individual IV:6 had 1 confirmed affected parent (III:5), and the phenotype of the other (deceased) parent was undetermined, so this individual could be heterozygous or potentially homozygous for the minor associated allele. Across the linkage interval on

chromosome 12, we found that 4 nonsynonymous and 1 untranslated region variant matched this genotype expectation. All of these variants were previously identified in the 1000 Genomes Project (<http://www.1000genomes.org/>, phase 1 call set, February 2012). We tested these 5 variants for association with SNHL in a stepwise regression model selection procedure in SOLAR<sup>18</sup> using proxy variants selected from the Affymetrix SNP chip panel when needed (SNP Annotation and Proxy Search, <http://www.broadinstitute.org/mpg/snap/>) for all 20 individuals included in the initial linkage analysis. We

Figure 3. Genome-Wide Linkage Plot

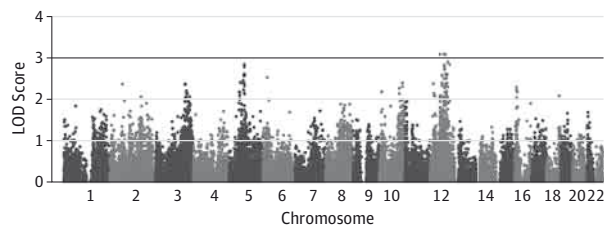

The logarithm of odds (LOD) score from a 2-point linkage analysis of all 631 644 single-nucleotide polymorphisms in 20 individuals of the sensorineural hearing loss family are shown relative to the chromosomal location of each variant.

used a bayesian model selection procedure<sup>14</sup> to identify the minimal number of variants likely to contribute to variation in the trait. The most parsimonious association model contained only 1 variant, *rs35725509*, in exon 3 of the *TMT2* gene ( $P = 2.28 \times 10^{-6}$ ,  $N = 20$ ). This model had a posterior probability of 1 for the association with the single variant; no other variant tested had a posterior probability of association exceeding 0.42 (and the other variants were not in substantial LD with *rs35725509*).

We did not uncover any putative functional (nonsynonymous) sequence variants in the genes *PTPRQ* and *OTOGL*, the 2 genes in the linkage interval previously implicated in an autosomal recessive form of SNHL (the *DFNB84* locus) that matched the expected genotype distribution for the sequenced individuals. The 2 genes are more than 2 Mb away from the *rs35725509* variant in *TMT2*, making it unlikely that long-range LD between the variant in *TMT2* and a causal variant in either of these 2 genes led to the result we obtained in our association analysis.

To validate the association of the variant *rs35725509* with SNHL in the family, we genotyped 47 individuals from the family (all 32 individuals highlighted in Figure 1 and an additional 15 unaffected descendants of individual III:5 and found a total of 13 affected individuals) and 40 control Centre d'Etude du Polymorphisme Humain DNA samples. All unaffected family members and Centre d'Etude du Polymorphisme Humain DNA samples were homozygous for the wild-type G allele, and 11 of 12 affected individuals were heterozygous. One affected individual (individual IV:7) was homozygous for the alternate A allele. Although homozygous, the hearing loss phenotype for individual IV:7 was not more severe compared with other family members (Table). The genotypes for all 6 individuals who underwent sequencing (III:7, III:8, IV:6, IV:9, V:7, and V:11) were confirmed, and no discrepancies were uncovered between the sequencing and genotyping data. The variant revealed a strong association with SNHL ( $P = 6 \times 10^{-13}$ ,  $N = 47$ ) in the extended family, and no residual heritability remained when the variant was included in the association model, suggesting that this gene region is responsible for a fully penetrant form of autosomal dominant SNHL in this family.

Because the identified variant in *TMT2*, *rs35725509*, has been detected in the 1000 Genomes and Exome Sequencing (<http://evs.gs.washington.edu/EVS/>) European call

Figure 4. Reverse Transcription–Polymerase Chain Reaction Gene Expression Analysis From Human Inner Ear Tissue

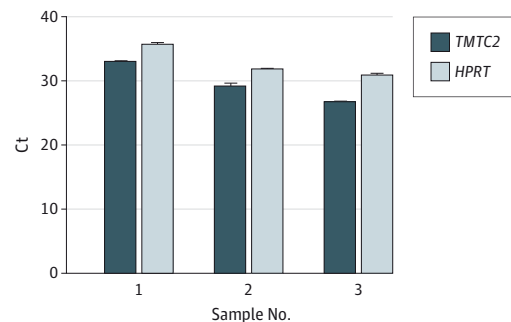

Cycle threshold (Ct) values for *TMT2* are shown in dark blue, and Ct values for a reference gene, *HPRT*, are shown in light blue. Higher Ct values indicate lower gene expression levels. No target and no reverse transcription controls had no signal after 50 cycles. Error bars indicate SE.

sets (1% and 0.8% frequency, respectively), it is possible that the variant may be associated with SNHL in other patients beyond the initial family. This finding is further supported by the family data because individual IV:7 is homozygous for the mutation, suggesting that her father, who married into the family, was a carrier for the mutation as well (no DNA or phenotypic information was available from this deceased individual). DNA analysis from the 179 unrelated volunteers with confirmed SNHL revealed an allele frequency for the minor A allele of 0.031, with 11 individuals being heterozygous for the sequence variant. In contrast, of the 186 patients of Northern European descent from the Midwestern United States who self-reported not having deafness, 184 were homozygous for the G allele of *rs35725509* ( $P = 7 \times 10^{-4}$ ). Two individuals had the minor A allele; however, on follow-up to confirm hearing status, 1 individual (currently deceased) was reported by family members to have worn hearing aids, and the other individual was unable to be contacted. The combined data confirm that the variant *rs35725509* is strongly associated with SNHL in both the original family and the general population; therefore, *TMT2* likely represents a novel gene affecting hearing in humans.

Analysis of an expressed sequence tag profiling human gene expression database (<http://www.ncbi.nlm.nih.gov/unigene/>) revealed expression of *TMT2* in 21 of 45 tissues examined, including adipose tissue, kidney, heart, and intestine; however, no expressed sequence tags of *TMT2* were detected in ear tissue. Likewise, the Mouse Genome Informatics website (<http://www.informatics.jax.org/>) reports expression of *TMT2* in 40 different tissues but not in ear or cochlear tissue. We collected cochlear tissue samples from 3 human cadavers, and reverse transcription–polymerase chain reaction analysis confirmed robust expression of *TMT2* in these samples when compared with expression of *HPRT* (OMIM 308000), a gene known to be expressed in the inner ear of humans,<sup>19</sup> further validating the gene as a potential regulator of normal hearing function (Figure 4).

## Discussion

Our analysis of a large family with SNHL revealed a previously uncharacterized gene that is likely to affect normal hearing and inner ear function. Interestingly, the identified variant in *TMTC2*, rs35725509, is strongly associated with SNHL not only in the original family but also in the general population, suggesting that the gene plays an important role in regulating and maintaining auditory function in humans. The specific function of *TMTC2* is unknown, but *TMTC2* is a transmembrane protein that contains 10 tetratricopeptide repeat motifs (<http://www.uniprot.org/uniprot/Q8N394>) and a structural motif that consists of 34 degenerate amino acids. The motif is found in a number of proteins and mediates protein-protein interaction (<http://www.uniprot.org/keywords/KW-0802>). A previous study<sup>20</sup> localized *TMTC2* to the endoplasmic reticulum in HEK293 cells and found it to be associated with the endoplasmic reticulum calcium uptake pump SERCA2B, but the detailed function of the protein and its putative role in other tissues have not been elucidated. It is possible that *TMTC2* is involved in a novel mechanism that affects hearing in humans.

The variant rs35725509 in *TMTC2* may not actually be causing the observed hearing loss in the family because the mutation is found in a relatively high percentage of individuals of Northern European descent in the 1000 Genomes and Exome Sequencing (<http://evs.gs.washington.edu/EVS/>) European call sets (1% and 0.8%, respectively). The *TMTC2* gene spans a genomic interval of 447 kb on human chromosome 12. The exome capture did not cover the 5' and 3' untranslated regions or any of the putative regulatory upstream or intronic sequences of *TMTC2*. The sequence variant rs35725509 is located in an LD block that spans 28 kb around exon 3 and has long-range LD with other SNPs in adjacent regions of *TMTC2*, suggesting that the mutation (or mutations) causing SNHL in this family may be located in other regions of the gene. However, there is no evidence that the LD extends beyond the *TMTC2* gene region, and any causal variant would be located in this gene. Future studies and sequencing

analyses are needed to identify the true causal sequence variant (or multiple variants) in the family and other patients with SNHL to fully assess the role of *TMTC2* mutations in SNHL in the general population. Additional functional studies will need to elucidate the role of *TMTC2* in normal auditory function to determine whether this novel gene may provide clues for alternative novel treatment approaches in the future.

To date, 53 loci and 31 genes have been identified in which mutations cause nonsyndromic autosomal dominant SNHL (<http://hereditaryhearingloss.org>). Only 2 of all the nonsynonymous mutations reported for these genes (Val306Met and Gly662Glu in *MYO1A* [OMIM 601478]) are found at frequencies comparable to rs35725509 in *TMTC2* in the general population, as assessed from the National Heart, Lung, and Blood Institute Exome Resequencing data (1.0% and 3.8%, respectively); all others are extremely rare and often specific to a single family. The audiometric configuration and progression patterns in this family are similar to phenotypes described for *DFNA2* (OMIM 603537), particularly for *KCNQ4* (OMIM 603537) pore-region mutations W276S in Dutch and Japanese families<sup>12,21,22</sup> and G285C in a US family.<sup>23,24</sup> We did not identify any nonsynonymous variants that matched the expected genotypes for the included individuals in any of the other previously reported genes and loci causing autosomal dominant SNHL, including *KCNQ4* at the *DNFA2* locus, suggesting that a mutation in the gene *TMTC2* is likely responsible for the observed hearing loss. This finding, again, suggests that this novel mutation may be an important contributor to autosomal dominant SNHL.

## Conclusions

A previously uncharacterized gene, *TMTC2*, was identified as a candidate for causing progressive SNHL in humans. This finding provides a more detailed understanding of the genetic basis of SNHL and reveals a potentially new, uncharacterized mechanism of hearing loss. Ultimately, these results contribute to improving our diagnostic capabilities and reveal targets for more effective treatment strategies for SNHL.

### ARTICLE INFORMATION

**Accepted for Publication:** April 19, 2016.

**Published Online:** June 16, 2016.

doi:10.1001/jamaoto.2016.1444.

**Author Affiliations:** Department of Otolaryngology and Communication Sciences, Medical College of Wisconsin, Milwaukee (Runge, King, Erbe, Kerschner, Friedland); Department of Biology, Boston College, Chestnut Hill, Massachusetts (Indap); Department of Pharmacology and Toxicology, Medical College of Wisconsin, Milwaukee (Zhou, Kwok); Department of Genetics, Texas Biomedical Research Institute, San Antonio (Kent, Göring, Olivier); Biotechnology and Bioengineering Center, Medical College of Wisconsin, Milwaukee (Cole, Littrell, Merath, James, Olivier); Max Delbrück Center for Molecular Medicine, Berlin-Buch, Germany (Rüschendorf, Hübner); Department of Human Genetics,

University of Utah School of Medicine, Salt Lake City (Marth); Department of Anesthesiology, Medical College of Wisconsin, Milwaukee (Kwok).

**Author Contributions:** Drs Runge and Olivier had full access to all the data in the study and take responsibility for the integrity of the data and the accuracy of the data analysis.

**Study concept and design:** Runge, Merath, Kerschner, Kwok, Olivier.

**Acquisition, analysis, or interpretation of data:** Runge, Indap, Zhou, Kent, King, Erbe, Cole, Littrell, Merath, James, Rüschendorf, Marth, Hübner, Göring, Friedland, Kwok, Olivier.

**Drafting of the manuscript:** Runge, Indap, Kent, Kwok, Olivier.

**Critical revision of the manuscript for important intellectual content:** Runge, Indap, Zhou, King, Erbe, Cole, Littrell, Merath, James, Rüschendorf, Kerschner, Marth, Hübner, Göring, Friedland, Olivier.

**Statistical analysis:** Zhou, Kent, Cole, Merath, Rüschendorf, Marth, Olivier.

**Obtained funding:** Runge, Marth.

**Administrative, technical, or material support:** Runge, Erbe, Cole, Littrell, James, Kerschner, Hübner, Friedland, Olivier.

**Study supervision:** Runge, Kerschner, Olivier.

**Conflict of Interest Disclosures:** All authors have completed and submitted the ICMJE Form for Disclosure of Potential Conflicts of Interest. Dr Runge reported working as a research consultant for Novartis Corp, Frequency Therapeutics Inc, and MED-EL Corp. Dr Olivier reported having grants from the National Institutes of Health during the conduct of the study. No other disclosures were reported.

**Funding/Support:** This work was funded by grant K23DC008837 from the National Institute on Deafness and Other Communication Disorders, National Institutes of Health (Dr Runge).

**Role of the Funder/Sponsor:** The funding source had no role in the design and conduct of the study; collection, management, analysis, and interpretation of the data; preparation, review, or approval of the manuscript; and the decision to submit the manuscript for publication.

**Previous Presentation:** This study was presented at the Annual Meeting of the American Society of Human Genetics; October 21, 2014; San Diego, California.

**Additional Contributions:** We acknowledge the Koss Cochlear Implant Program at the Medical College of Wisconsin and the Koss Hearing and Balance Center at Froedtert and the Medical College of Wisconsin. Technical support for SNP genotyping and sequencing was provided by the Human and Molecular Genetics Center, Medical College of Wisconsin. Special thanks to the family members who gave permission for publication, and without whom this study would have been impossible, and TOPS Inc, who supported the Metabolic Risk Complications of Obesity Genes Study at the Medical College of Wisconsin that provided control individuals with self-reported nondeafness. We also thank Sarah Mleziva, BS, Linda S. Burg, AuD, and Jamie J. Jensen, AuD, Department of Otolaryngology, Medical College of Wisconsin, who contributed to the data collection and subject accrual. Dr Burg serves on the MED-EL Audiology Advisory Board, and Dr Jensen serves on the Advanced Bionics Corp. Audiology Advisory Board. Drs Burg and Jensen received compensation for their advisory board roles, but the amounts are not significant.

## REFERENCES

- Marazita ML, Ploughman LM, Rawlings B, Remington E, Arnos KS, Nance WE. Genetic epidemiological studies of early-onset deafness in the U.S. school-age population. *Am J Med Genet.* 1993;46(5):486-491.
- Morton NE. Genetic epidemiology of hearing impairment. *Ann N Y Acad Sci.* 1991;630:16-31.
- Boulet SL, Boyle CA, Schieve LA. Health care use and health and functional impact of developmental disabilities among US children, 1997-2005. *Arch Pediatr Adolesc Med.* 2009;163(1):19-26.
- National Institute on Deafness and Other Communication Disorders. Health information. <https://www.nidcd.nih.gov/health/statistics/Pages/quick.asp>. Accessed December 15, 2015.
- Bacino C, Prezant TR, Bu X, Fournier P, Fischel-Ghodsian N. Susceptibility mutations in the mitochondrial small ribosomal RNA gene in aminoglycoside induced deafness. *Pharmacogenetics.* 1995;5(3):165-172.
- Fischel-Ghodsian N, Prezant TR, Chaltraw WE, et al. Mitochondrial gene mutation is a significant predisposing factor in aminoglycoside ototoxicity. *Am J Otolaryngol.* 1997;18(3):173-178.
- Lin CY, Shih TS, Guo YL, Wu JL, Sun YM, Tsai PJ. Effects of gene-environmental interaction on noise-induced hearing threshold levels for high frequencies (HTLHF). *Environ Sci Technol.* 2011;45(17):7128-7134.
- Van Eyken E, Van Camp G, Fransen E, et al. Contribution of the *N*-acetyltransferase 2 polymorphism NAT2\*6A to age-related hearing impairment. *J Med Genet.* 2007;44(9):570-578.
- Van Camp G, Smith R. Hereditary Hearing Loss Homepage. <http://hereditaryhearingloss.org>. Accessed March 27, 2016.
- Alford RL, Arnos KS, Fox M, et al; ACMG Working Group on Update of Genetics Evaluation Guidelines for the Etiologic Diagnosis of Congenital Hearing Loss; Professional Practice and Guidelines Committee. American College of Medical Genetics and Genomics guideline for the clinical evaluation and etiologic diagnosis of hearing loss. *Genet Med.* 2014;16(4):347-355.
- Morton CC, Nance WE. Newborn hearing screening: a silent revolution. *N Engl J Med.* 2006;354(20):2151-2164.
- Topsakal V, Pennings RJ, te Brinke H, et al. Phenotype determination guides swift genotyping of a *DFNA2/KCNQ4* family with a hot spot mutation (W276S). *Otol Neurotol.* 2005;26(1):52-58.
- Sobel E, Lange K. Descent graphs in pedigree analysis: applications to haplotyping, location scores, and marker-sharing statistics. *Am J Hum Genet.* 1996;58(6):1323-1337.
- Almasy L, Blangero J. Multipoint quantitative-trait linkage analysis in general pedigrees. *Am J Hum Genet.* 1998;62(5):1198-1211.
- Williams JT, Blangero J. Power of variance component linkage analysis. II: discrete traits. *Ann Hum Genet.* 2004;68(Pt 6):620-632.
- Olivier M. The Invader assay for SNP genotyping. *Mutat Res.* 2005;573(1-2):103-110.
- Zhang Y, Smith E, Olivier M. Putting the Invader assay to work: laboratory application and data management. *Methods Mol Biol.* 2009;578:363-377.
- Blangero J, Goring HH, Kent JW Jr, et al. Quantitative trait nucleotide analysis using Bayesian model selection. *Hum Biol.* 2005;77(5):541-559.
- Ubell ML, Kerschner JE, Wackym PA, Burrows A. *MUC2* expression in human middle ear epithelium of patients with otitis media. *Arch Otolaryngol Head Neck Surg.* 2008;134(1):39-44.
- Sunryd JC, Cheon B, Graham JB, Giorda KM, Fissore RA, Hebert DN. *TMTC1* and *TMTC2* are novel endoplasmic reticulum tetratricopeptide repeat-containing adapter proteins involved in calcium homeostasis. *J Biol Chem.* 2014;289(23):16085-16099.
- De Leenheer EM, Huygen PL, Coucke PJ, Admiraal RJ, van Camp G, Cremers CW. Longitudinal and cross-sectional phenotype analysis in a new, large Dutch *DFNA2/KCNQ4* family. *Ann Otol Rhinol Laryngol.* 2002;111(3, pt 1):267-274.
- Akita J, Abe S, Shinkawa H, Kimberling WJ, Usami S. Clinical and genetic features of nonsyndromic autosomal dominant sensorineural hearing loss: *KCNQ4* is a gene responsible in Japanese. *J Hum Genet.* 2001;46(7):355-361.
- Coucke P, Van Camp G, Djyodiharjo B, et al. Linkage of autosomal dominant hearing loss to the short arm of chromosome 1 in two families. *N Engl J Med.* 1994;331(7):425-431.
- Coucke PJ, Van Hauwe P, Kelley PM, et al. Mutations in the *KCNQ4* gene are responsible for autosomal dominant deafness in four *DFNA2* families. *Hum Mol Genet.* 1999;8(7):1321-1328.